

Pedestrian stacker truck 1.2 ton

BT staxio

W-series

SWE120XR

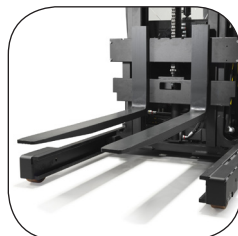

Pedestrian stacker

Specifications					SWE120XR	
Identification	1.1	Manufacturer				BT
	1.2	Model				SWE120XR
	1.3	Drive				Electric
	1.4	Operator type				Pedestrian
	1.5	Load capacity/rated load	Q	kg		1200
	1.6	Load center	c	mm		600
	1.8	Load distance, centre of support arm wheel to face of forks	x	mm		DXT/DXH=677, TX=660
	1.9	Wheelbase	y	mm		1505
	Weight	2.1	Service weight incl. battery		kg	
2.3		Axle load, mast retracted without load, drive/fork wheel		kg		1220/610
2.4		Axle load, mast extended with load, drive/fork wheel		kg		230/2800
2.5		Axle load, mast retracted with load, drive/fork wheel		kg		1200/1830
Wheels		3.1	Drive/caster/fork wheel			
	3.2	Wheel size, front		mm		250
	3.3	Wheel size, rear		mm		140
	3.7	Track width, rear	b ₁₁	mm		810/995
Dimensions	4.2	Height, mast lowered	h ₁	mm		2224
	4.3	Free lift	h ₂	mm		1734
	4.4	Lift	h ₃	mm		4750
		Lift height	h ₂₃	mm		4800
	4.5	Height, mast extended	h ₄	mm		5320
	4.9	Height of tiller in drive position, min./max.	h ₁₄	mm		950/1360
	4.10	Height of support arms	h ₈	mm		160
	4.15	Height, fork lowered	h ₁₃	mm		50
	4.19	Overall length	l	mm		1992
	4.20	Length to face of forks	l ₂	mm		995
	4.21	Overall width	b ₁ /b ₂	mm		900/1085
	4.22	Fork dimensions	s/e/l	mm		40/100/1150
	4.25	Width over forks	b ₅	mm		Wide=250-750, Narrow=250-570
	4.26	Distance between support arms	b ₄	mm		665/850
	4.28	Reach distance	l ₄	mm		790
	4.31	Ground clearance, center of wheelbase	m ₁	mm		30
	4.32	Ground clearance, center of wheelbase	m ₂	mm		40
	4.33	Aisle width for pallets 1000 × 1200 crossways	A _{st}	mm		2551
	4.34	Aisle width for pallets 800 × 1200 lengthways	A _{st}	mm		2528
4.35	Turning radius	W _a	mm		1670	
4.37	Length across support arms	l ₇	mm		1830	
Performance data	5.1	Travel speed, with/without load		km/h		6,0/6,0
	5.2	Lift speed, with/without load		m/s		0,20/0,36
	5.3	Lowering speed, with/without load		m/s		0,45/0,45
	5.4	Reach speed, with/without load		m/s		0,15/0,15
	5.8	Max. gradeability, with/without load ¹⁾		%		8/10
	5.9	Acceleration time (over 10 m)		s		6,8
	5.10	Service brake				Electromagnetic
Electric motor	6.1	Drive motor rating (S2 60min)				1,8
	6.2	Lift motor rating (S3 15%)		kW		3
	6.4	Battery voltage, nominal capacity K5		V/Ah		24/300
	6.5	Battery weight		kg		195-270
	6.6	Energy consumption acc to VDI cycle		kWh/h		1,21
	Others	8.1	Type of drive control			
8.4		Sound level at the driver's ear according to EN 12 053		dB (A)		59

1) Measured according to company standard.

Data is based on standard truck and small battery.

All data are based on table configuration. Other configurations may give other values.

Truck performance and dimensions are nominal and subject to tolerances.

Toyota Material Handling Manufacturing Sweden AB products and specifications are subject to change without notice.

Mast dimensions

SWE120XR			Duplex Tele							Duplex HiLo					Triplex HiLo					
h_{23}	Lift height ($h_{13}+h_3$)	mm	2300	2450	2750	3250	3650	4100	2350	2500	2800	3300	3700	4150	3300	3700	3950	4150	4500	4800
h_3	Lift	mm	2250	2400	2700	3200	3600	4050	2300	2450	2750	3250	3650	4100	3250	3650	3900	4100	4450	4750
h_1	Height, mast lowered	mm	1722	1797	1947	2197	2397	2622	1722	1797	1947	2197	2397	2622	1724	1857	1940	2007	2124	2224
h_2	Free lift	mm	132	132	132	132	132	132	1242	1316	1466	1716	1916	2142	1234	1366	1450	1516	1634	1734
h_4	Height, mast extended	mm	2798	2948	3248	3748	4148	4598	2880	3030	3330	3830	4230	4680	3820	4219	4468	4669	5020	5320

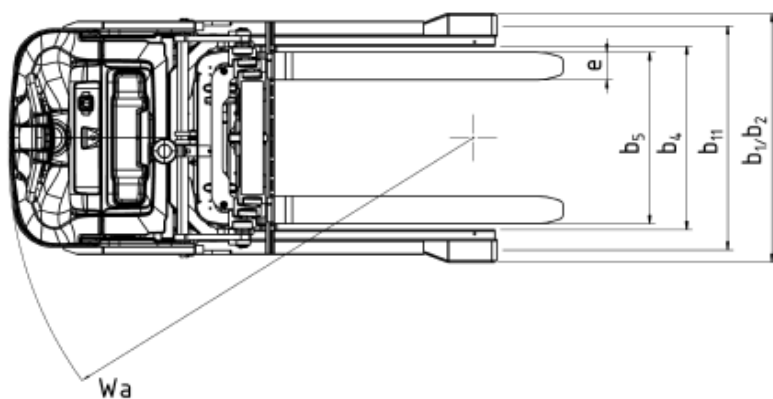
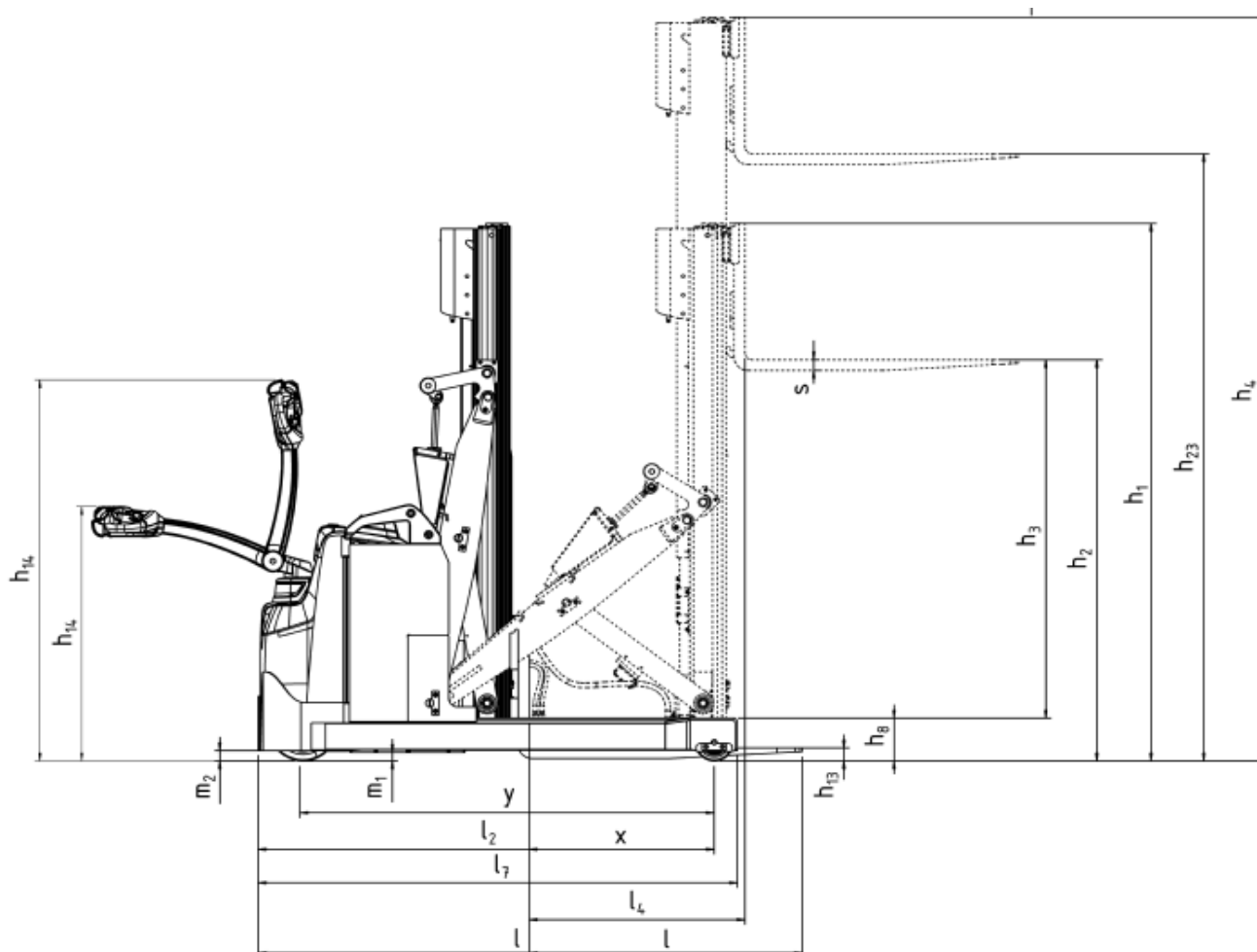

Truck features:

- 180°+ Power/Electronic steering
- Optimised Truck Performance
- Reach mast with Pantograph fork mechanism
- Mast tilt
- Adjustable fork width
- Sensi-lift
- Click-2-Creep
- Electronic fingertip controls for all functions
- Access control
- Driver-adapted programmable performance
- Easy access for maintenance
- Sideshift and spreader attachment (option)
- I_Site (option)
- Li-Ion battery (option)
- Coldstore version (option)

